

EFH Swisttal, DB

ÜBERSENDET VON

Uzeir Huskic
huskic-immobilien@gmx.de

ERSTELLT AM

2022-09-17

STANDORT

Weiherstraße 27
53913 Swisttal
Nordrhein-Westfalen
Deutschland



Stockwerke 3	Räume 11	Badezimmer 4
------------------------	--------------------	------------------------

▼ Kellergeschoss

RÄUME: 2

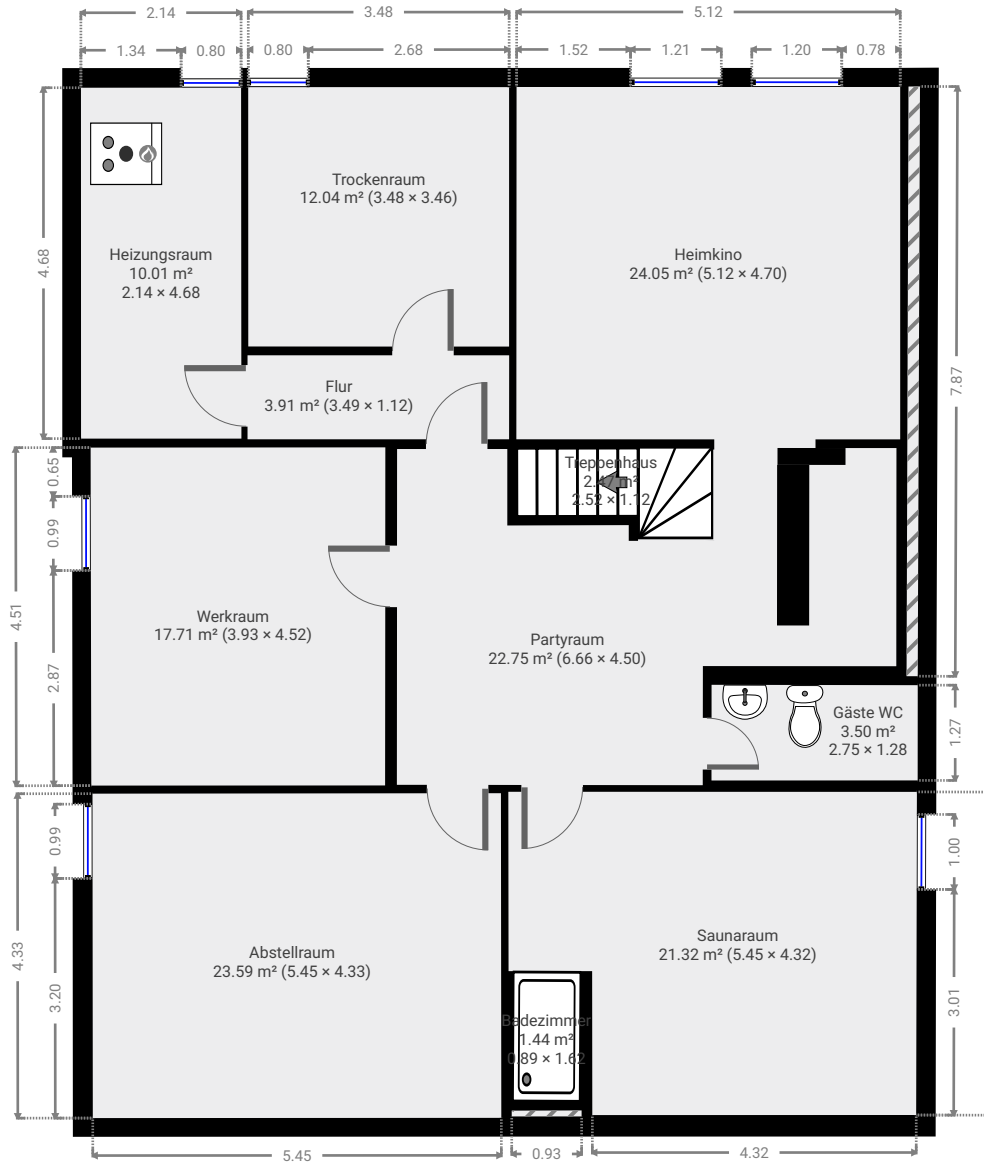

EFH Swisttal, DB

Weierstraße 27, 53913 Swisttal, Nordrhein-Westfalen, Deutschland
STOCKWERKE: 3 • RÄUME: 11

▼ Abstellraum Kellergeschoss

BREITE: 4.33 m • LÄNGE: 5.45 m
BEREICH: 23.59 m² • UMFANG: 19.56 m

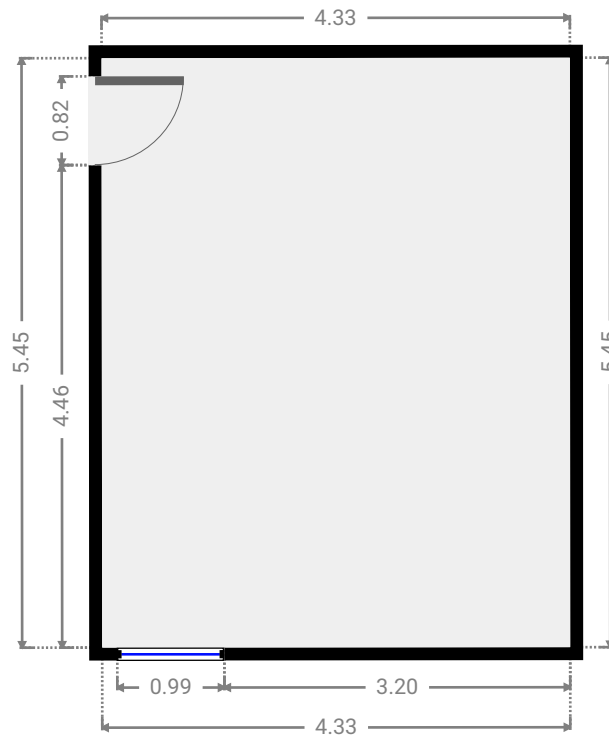
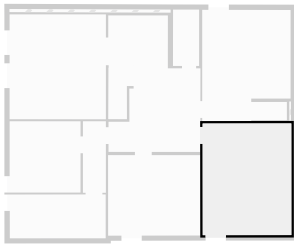

▼ Badezimmer Kellergeschoss

BREITE: 1.62 m • LÄNGE: 0.89 m
BEREICH: 1.44 m² • UMFANG: 5.02 m

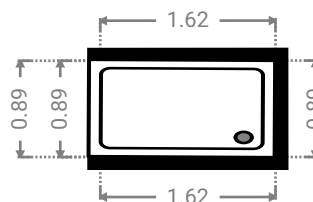
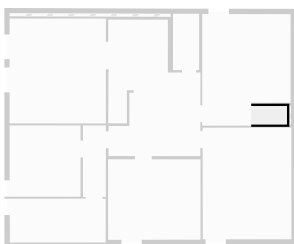

EFH Swisttal, DB

Weierstraße 27, 53913 Swisttal, Nordrhein-Westfalen, Deutschland
STOCKWERKE: 3 • RÄUME: 11

▼ Flur Kellergeschoss

BREITE: 1.12 m • LÄNGE: 3.49 m
BEREICH: 3.91 m² • UMFANG: 9.22 m

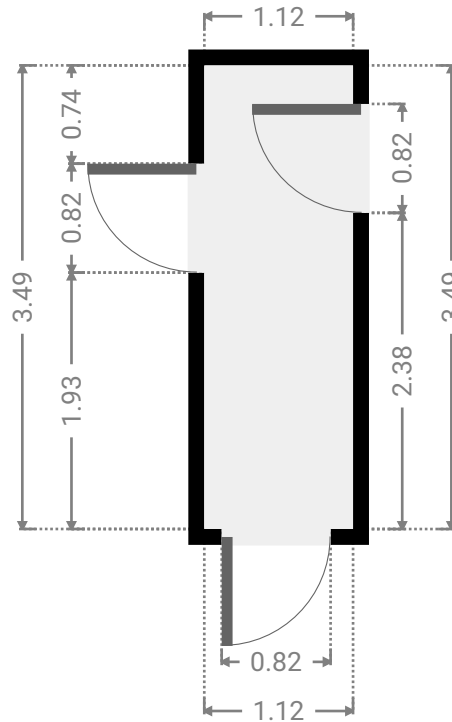
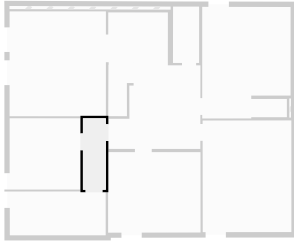

▼ Gäste WC Kellergeschoss

BREITE: 1.28 m • LÄNGE: 2.75 m
BEREICH: 3.50 m² • UMFANG: 8.05 m

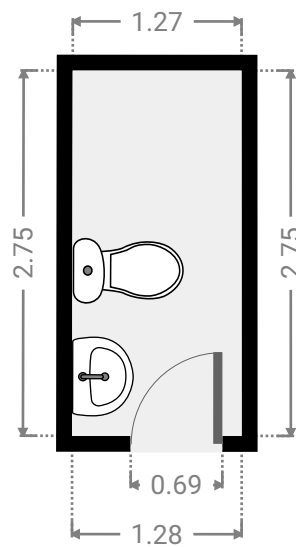
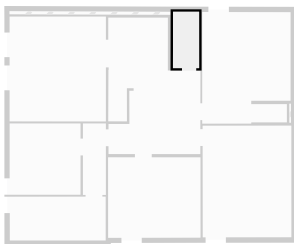

EFH Swisttal, DB

Weierstraße 27, 53913 Swisttal, Nordrhein-Westfalen, Deutschland
STOCKWERKE: 3 • RÄUME: 11



▼ Heimkino Kellergeschoss

BREITE: 4.70 m • LÄNGE: 5.12 m
BEREICH: 24.05 m² • UMFANG: 19.64 m

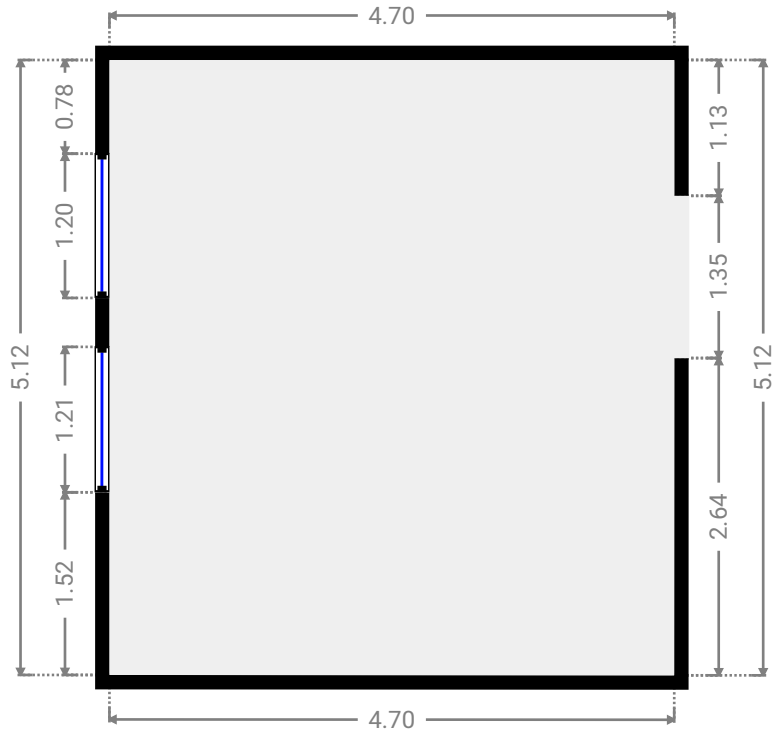
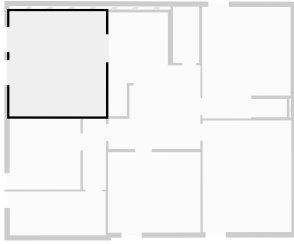

▼ Heizungsraum Kellergeschoss

BREITE: 4.68 m • LÄNGE: 2.14 m
BEREICH: 10.01 m² • UMFANG: 13.64 m

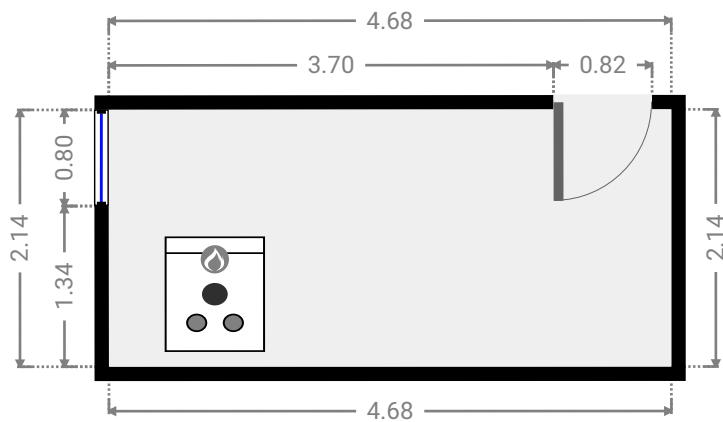
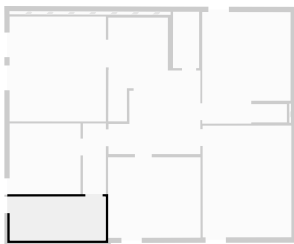

▼ Partyraum Kellergeschoss

BREITE: 4.50 m • LÄNGE: 6.66 m
BEREICH: 22.75 m² • UMFANG: 24.77 m

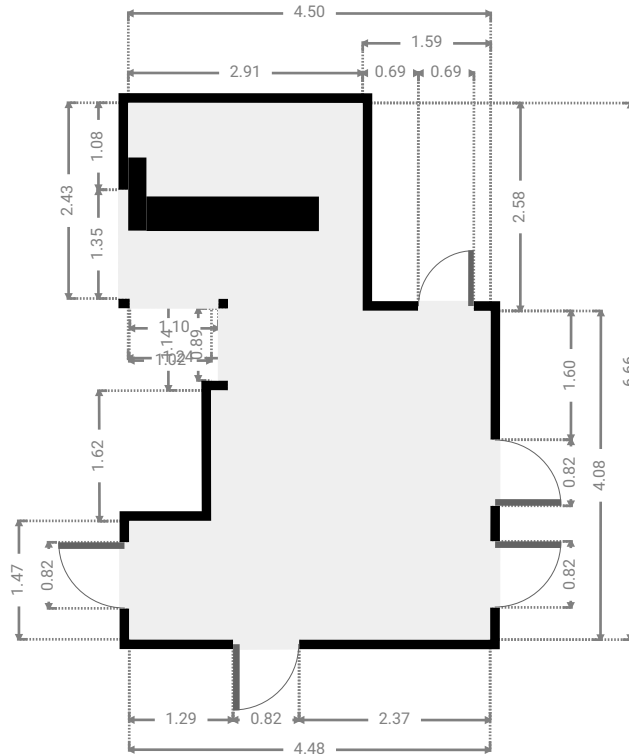
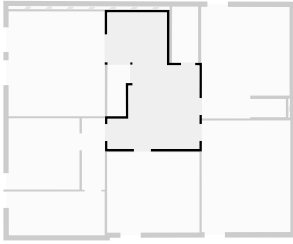

▼ Saunaraum Kellergeschoss

BREITE: 4.32 m • LÄNGE: 5.45 m
BEREICH: 21.32 m² • UMFANG: 19.51 m

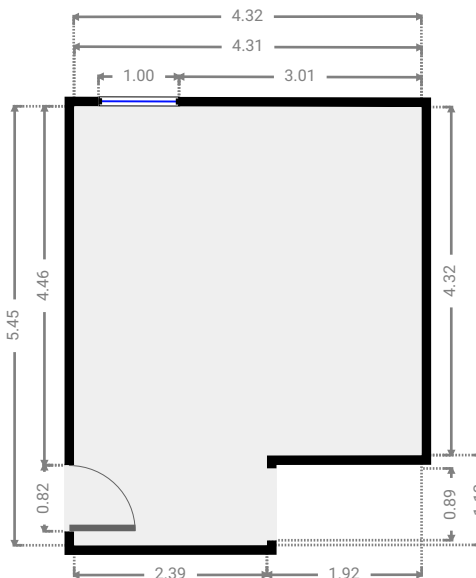
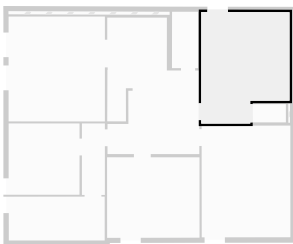

▼ Treppenhaus Kellergeschoss

BREITE: 1.12 m · LÄNGE: 2.52 m
BEREICH: 2.47 m² · UMFANG: 7.26 m

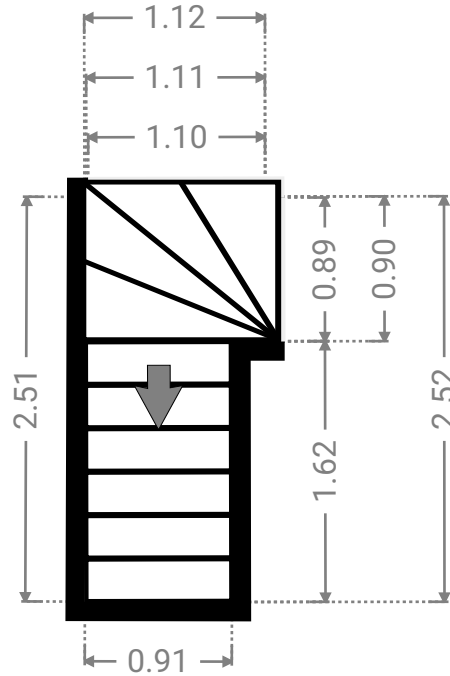
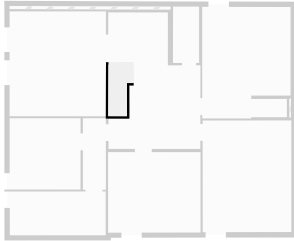

▼ Trockenraum Kellergeschoss

BREITE: 3.46 m · LÄNGE: 3.48 m
BEREICH: 12.04 m² · UMFANG: 13.88 m

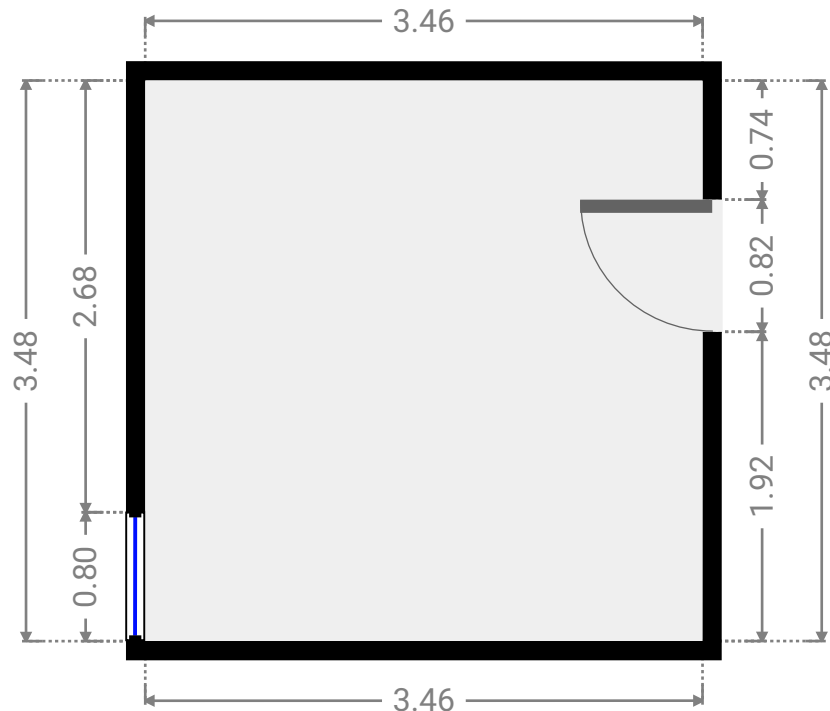
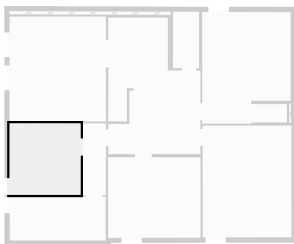

EFH Swisttal, DB

Weierstraße 27, 53913 Swisttal, Nordrhein-Westfalen, Deutschland
STOCKWERKE: 3 · RÄUME: 11



▼ Werkraum Kellergeschoss

BREITE: 4.52 m · LÄNGE: 3.93 m
BEREICH: 17.71 m² · UMFANG: 16.87 m

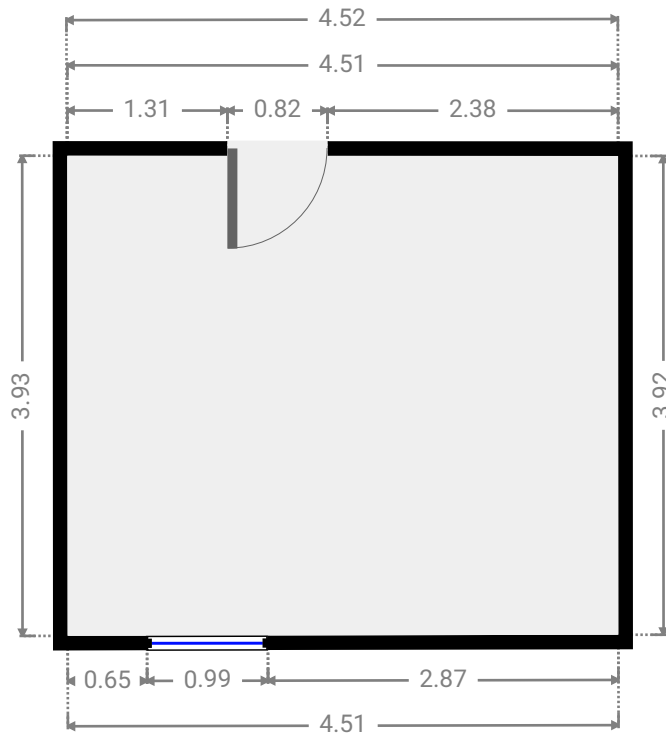
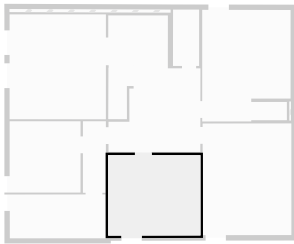

▼ Erdgeschoss

RÄUME: 4

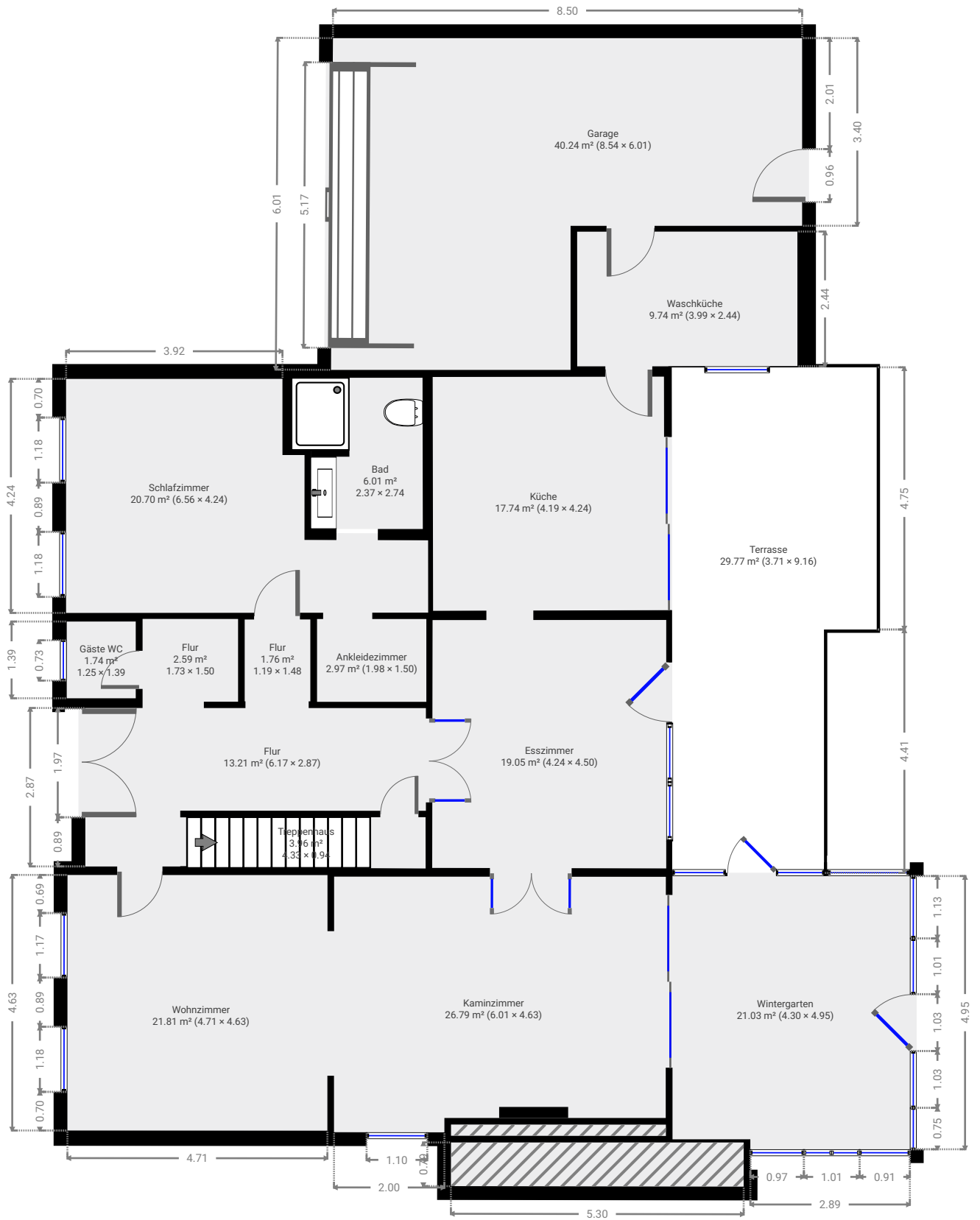

EFH Swisttal, DB

Weierstraße 27, 53913 Swisttal, Nordrhein-Westfalen, Deutschland
STOCKWERKE: 3 • RÄUME: 11

▼ Bad Erdgeschoss

BREITE: 2.74 m • LÄNGE: 2.37 m
BEREICH: 6.01 m² • UMFANG: 10.22 m

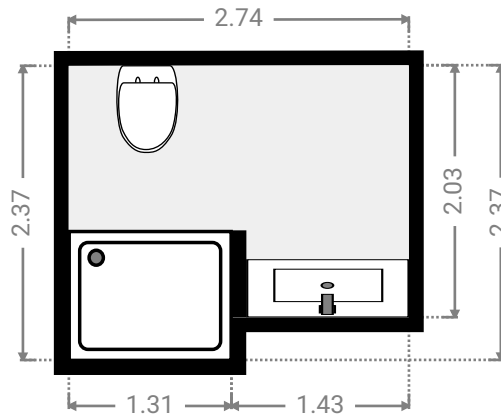
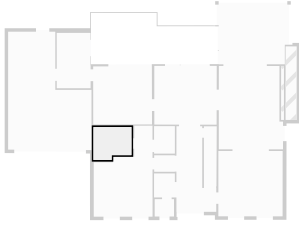

▼ Esszimmer Erdgeschoss

BREITE: 4.50 m • LÄNGE: 4.24 m
BEREICH: 19.05 m² • UMFANG: 17.46 m

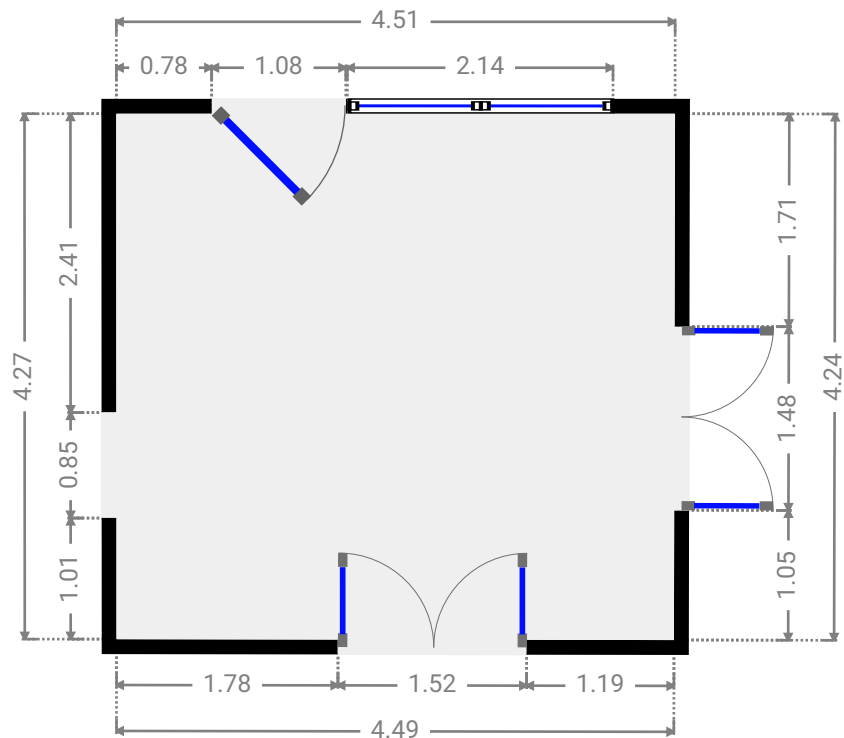
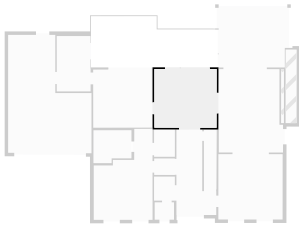

EFH Swisttal, DB

Weierstraße 27, 53913 Swisttal, Nordrhein-Westfalen, Deutschland
STOCKWERKE: 3 · RÄUME: 11

▼ Flur Erdgeschoss

BREITE: 1.50 m · LÄNGE: 1.73 m
BEREICH: 2.59 m² · UMFANG: 6.46 m

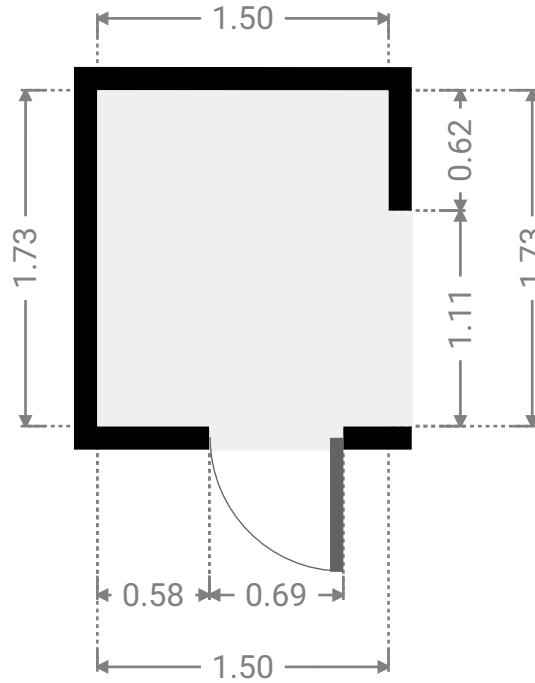
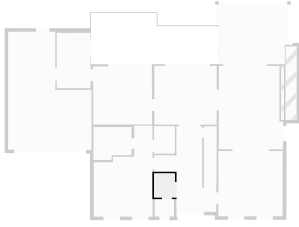

▼ Flur Erdgeschoss

BREITE: 1.48 m · LÄNGE: 1.19 m
BEREICH: 1.76 m² · UMFANG: 5.34 m

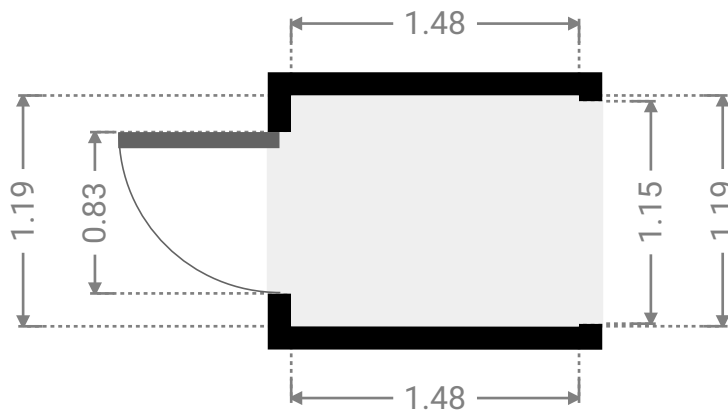

EFH Swisttal, DB

Weierstraße 27, 53913 Swisttal, Nordrhein-Westfalen, Deutschland
STOCKWERKE: 3 • RÄUME: 11



▼ Flur Erdgeschoss

BREITE: 2.87 m • LÄNGE: 6.17 m
BEREICH: 13.21 m² • UMFANG: 18.08 m

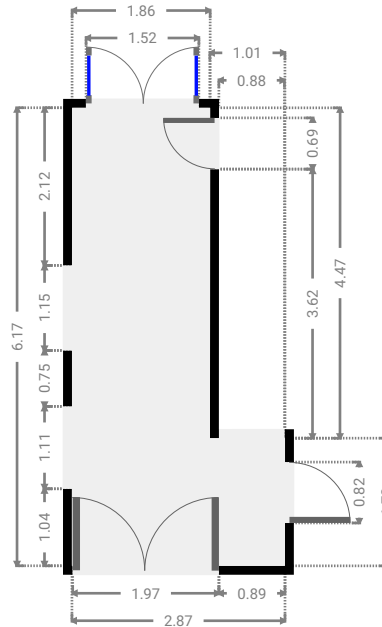

▼ Garage Erdgeschoss

BREITE: 6.01 m • LÄNGE: 8.54 m
BEREICH: 40.24 m² • UMFANG: 29.05 m

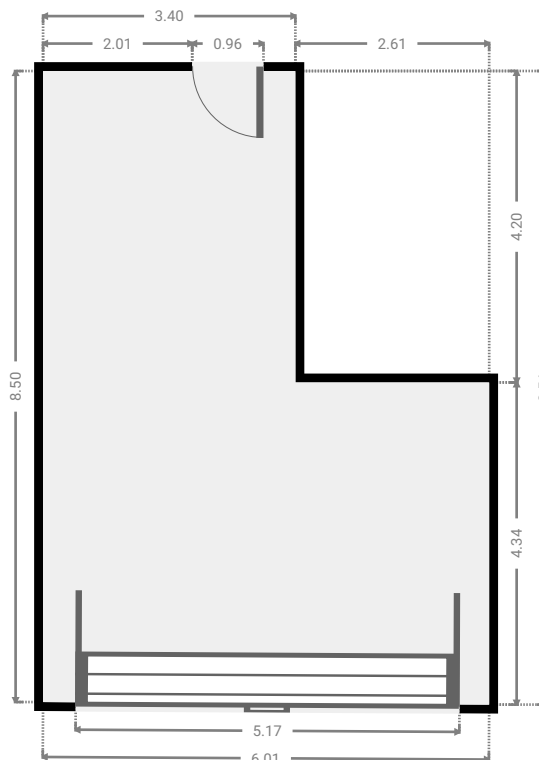
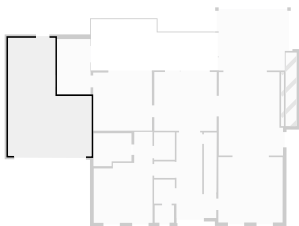

EFH Swisttal, DB

Weierstraße 27, 53913 Swisttal, Nordrhein-Westfalen, Deutschland
STOCKWERKE: 3 · RÄUME: 11



▼ Gäste WC Erdgeschoss

BREITE: 1.39 m · LÄNGE: 1.25 m
BEREICH: 1.74 m² · UMFANG: 5.28 m

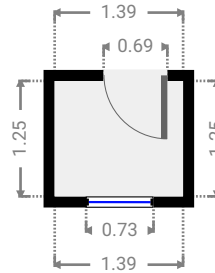
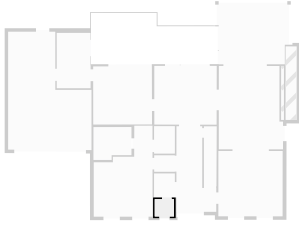

▼ Kaminzimmer Erdgeschoss

BREITE: 4.63 m · LÄNGE: 6.01 m
BEREICH: 26.79 m² · UMFANG: 21.28 m

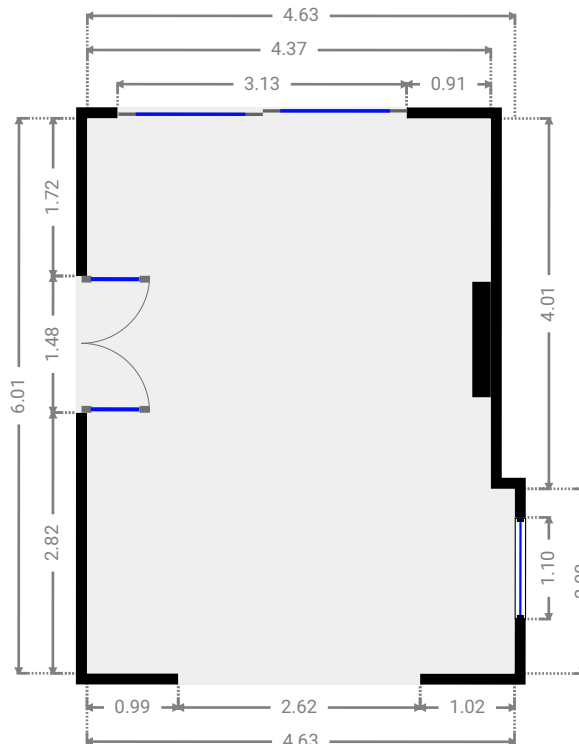
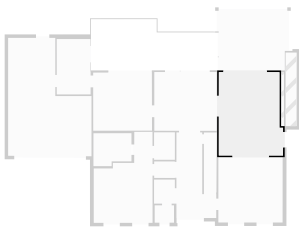

EFH Swisttal, DB

Weierstraße 27, 53913 Swisttal, Nordrhein-Westfalen, Deutschland
STOCKWERKE: 3 • RÄUME: 11



▼ Küche Erdgeschoss

BREITE: 4.24 m • LÄNGE: 4.19 m
BEREICH: 17.74 m² • UMFANG: 16.85 m

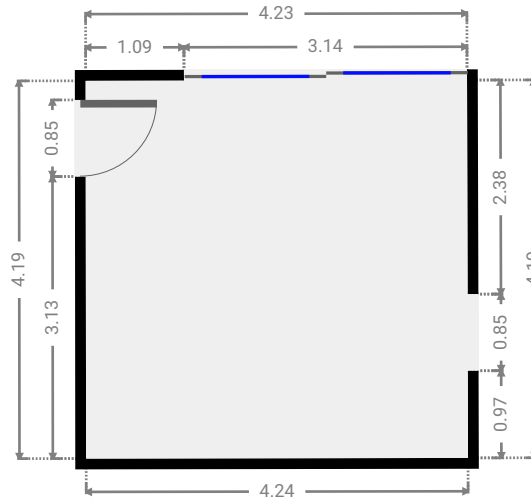
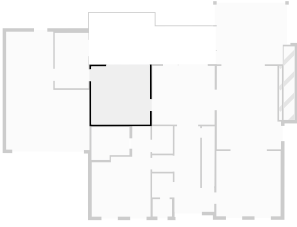

▼ Schlafzimmer Erdgeschoss

BREITE: 4.24 m • LÄNGE: 6.56 m
BEREICH: 20.70 m² • UMFANG: 21.59 m

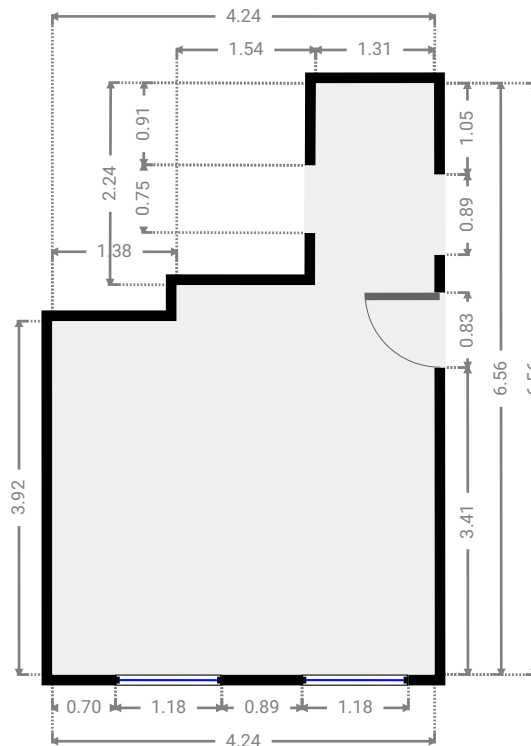

EFH Swisttal, DB

Weierstraße 27, 53913 Swisttal, Nordrhein-Westfalen, Deutschland
STOCKWERKE: 3 • RÄUME: 11

▼ Ankleidezimmer Erdgeschoss

BREITE: 1.50 m • LÄNGE: 1.98 m
BEREICH: 2.97 m² • UMFANG: 6.96 m

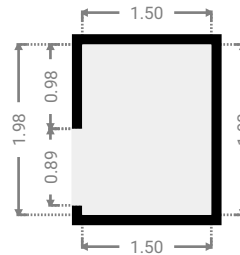
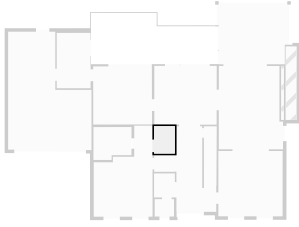

▼ Terrasse Erdgeschoss

BREITE: 9.16 m • LÄNGE: 3.71 m
BEREICH: 29.77 m² • UMFANG: 25.74 m

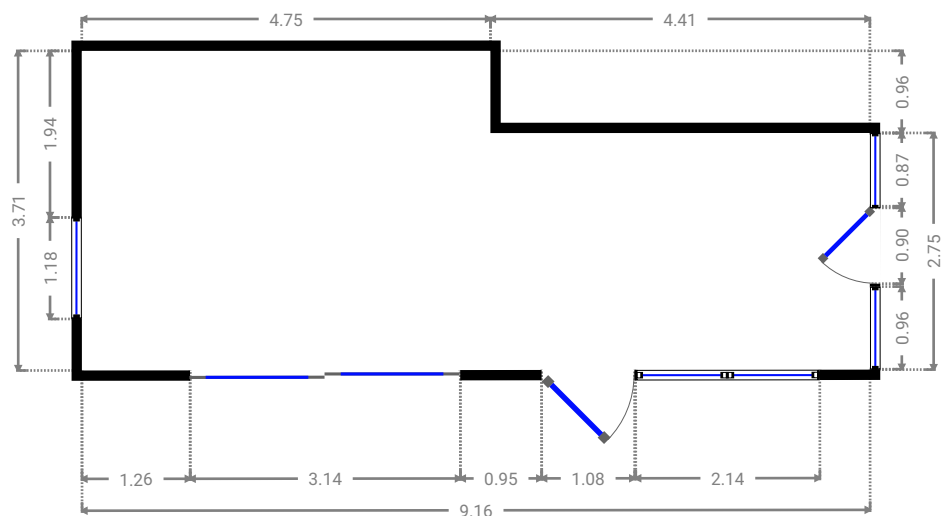

EFH Swisttal, DB

Weierstraße 27, 53913 Swisttal, Nordrhein-Westfalen, Deutschland
STOCKWERKE: 3 • RÄUME: 11



▼ Treppenhaus Erdgeschoss

BREITE: 0.94 m • LÄNGE: 4.33 m
BEREICH: 3.96 m² • UMFANG: 10.48 m

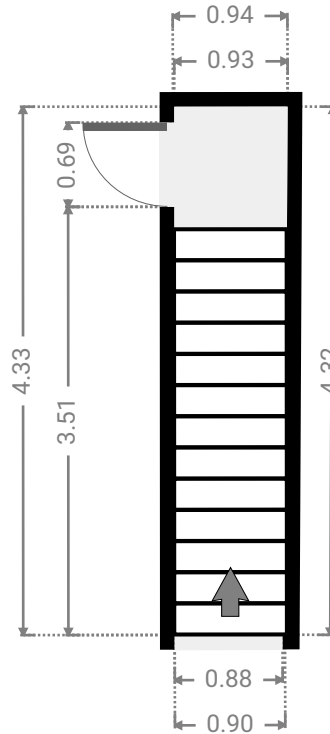
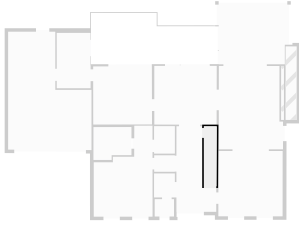

▼ Waschküche Erdgeschoss

BREITE: 2.44 m • LÄNGE: 3.99 m
BEREICH: 9.74 m² • UMFANG: 12.86 m

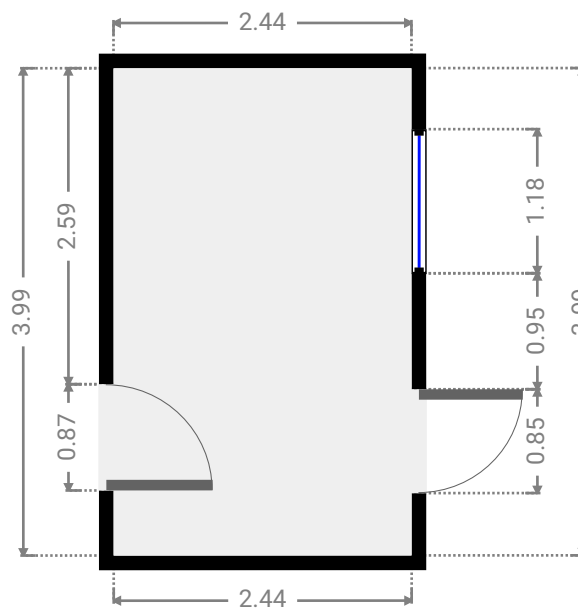
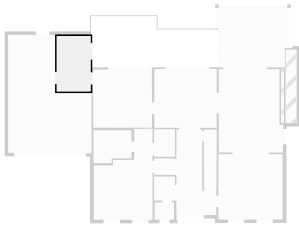

EFH Swisttal, DB

Weierstraße 27, 53913 Swisttal, Nordrhein-Westfalen, Deutschland
STOCKWERKE: 3 • RÄUME: 11



▼ Wintergarten Erdgeschoss

BREITE: 4.95 m • LÄNGE: 4.30 m
BEREICH: 21.03 m² • UMFANG: 18.50 m

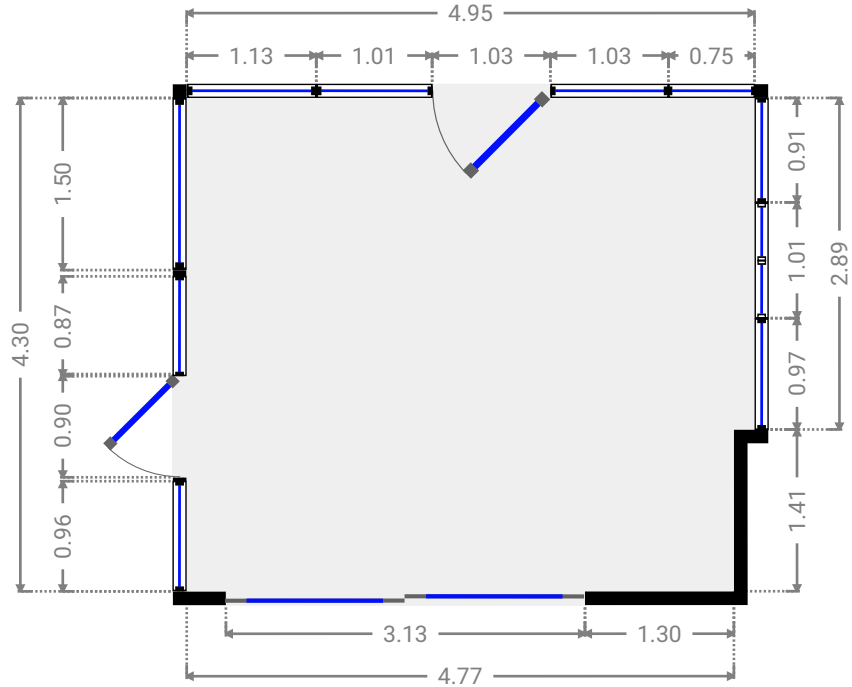

▼ Wohnzimmer Erdgeschoss

BREITE: 4.63 m • LÄNGE: 4.71 m
BEREICH: 21.81 m² • UMFANG: 18.68 m

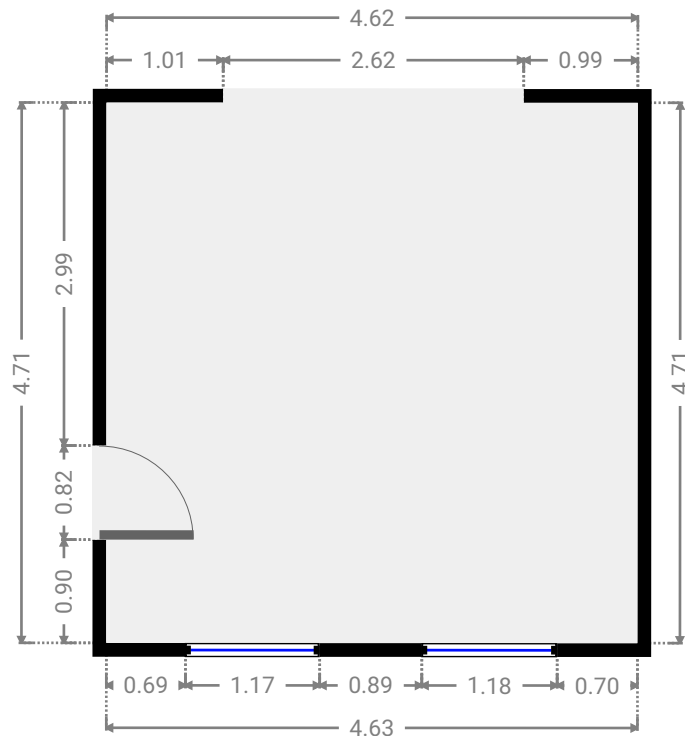

EFH Swisttal, DB

Weierstraße 27, 53913 Swisttal, Nordrhein-Westfalen, Deutschland
STOCKWERKE: 3 · RÄUME: 11

▼ 1. Stock

RÄUME: 5

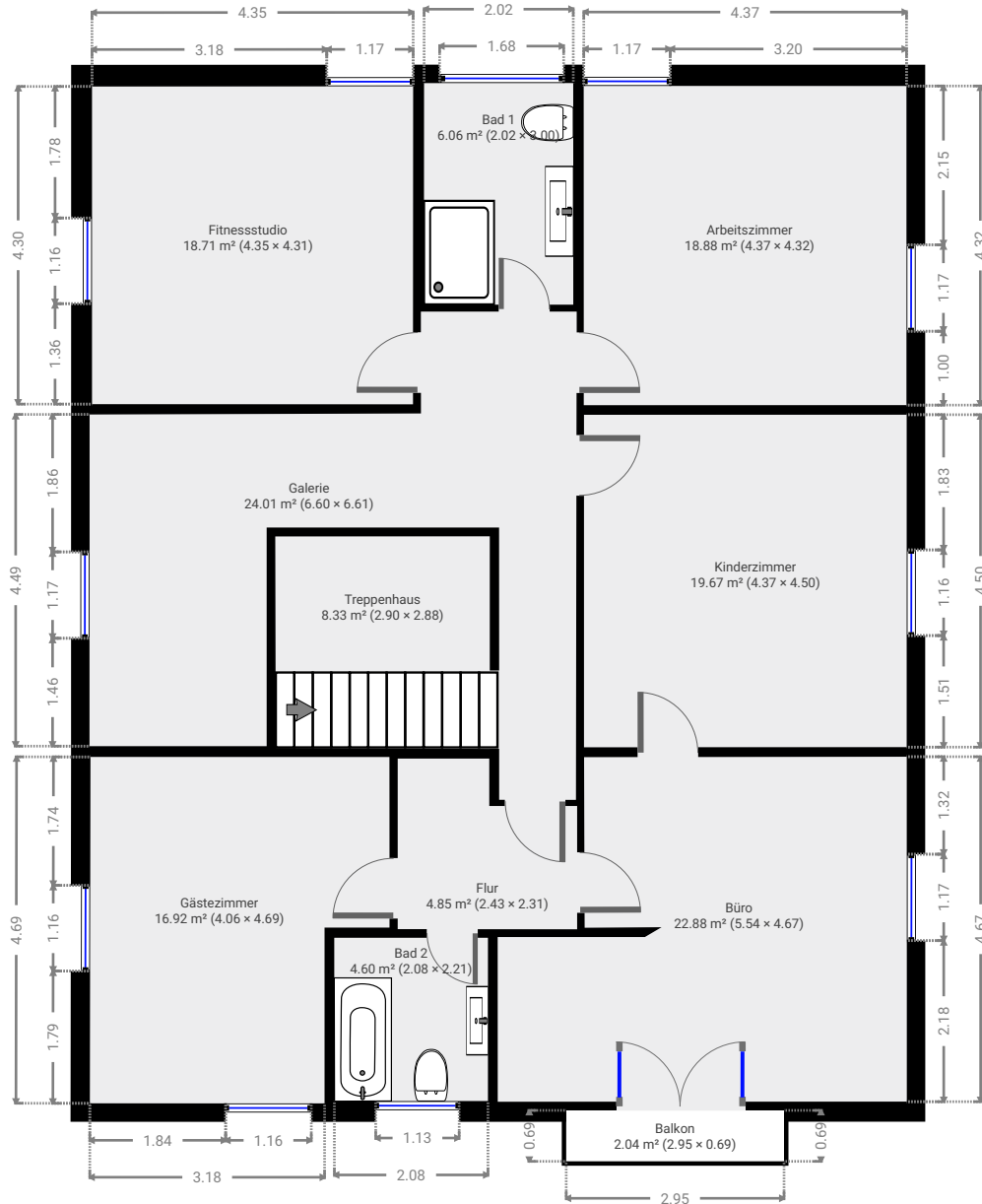

EFH Swisttal, DB

Weierstraße 27, 53913 Swisttal, Nordrhein-Westfalen, Deutschland
STOCKWERKE: 3 • RÄUME: 11



▼ Arbeitszimmer 1. Stock

BREITE: 4.32 m • LÄNGE: 4.37 m
BEREICH: 18.88 m² • UMFANG: 17.38 m

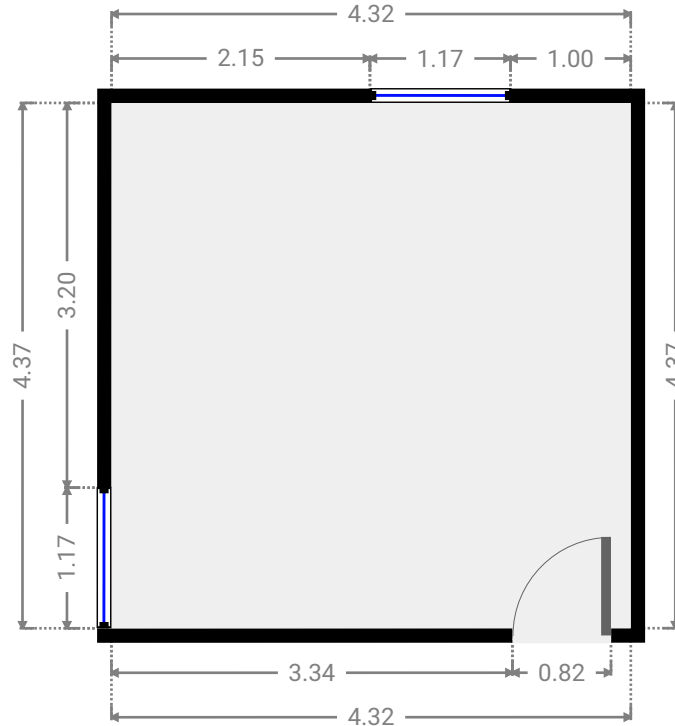
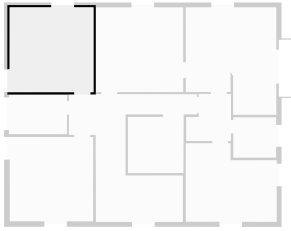

▼ Bad 1 1. Stock

BREITE: 3.00 m • LÄNGE: 2.02 m
BEREICH: 6.06 m² • UMFANG: 10.04 m

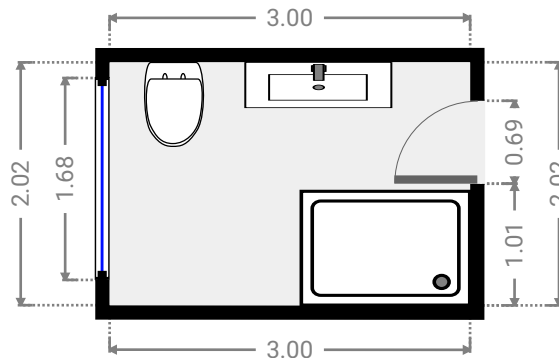
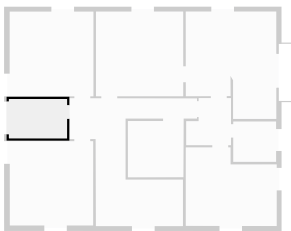

EFH Swisttal, DB

Weierstraße 27, 53913 Swisttal, Nordrhein-Westfalen, Deutschland
STOCKWERKE: 3 • RÄUME: 11

▼ Bad 2 1. Stock

BREITE: 2.21 m • LÄNGE: 2.08 m
BEREICH: 4.60 m² • UMFANG: 8.58 m

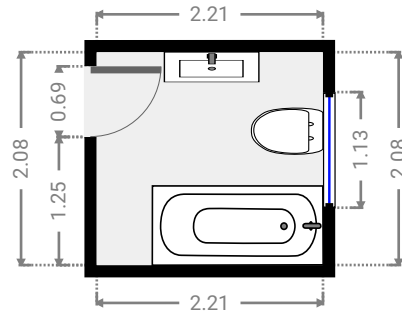
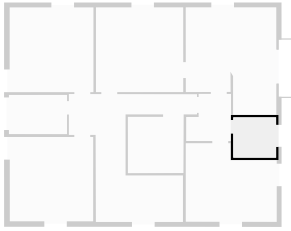

▼ Büro 1. Stock

BREITE: 4.67 m • LÄNGE: 5.54 m
BEREICH: 22.88 m² • UMFANG: 22.42 m

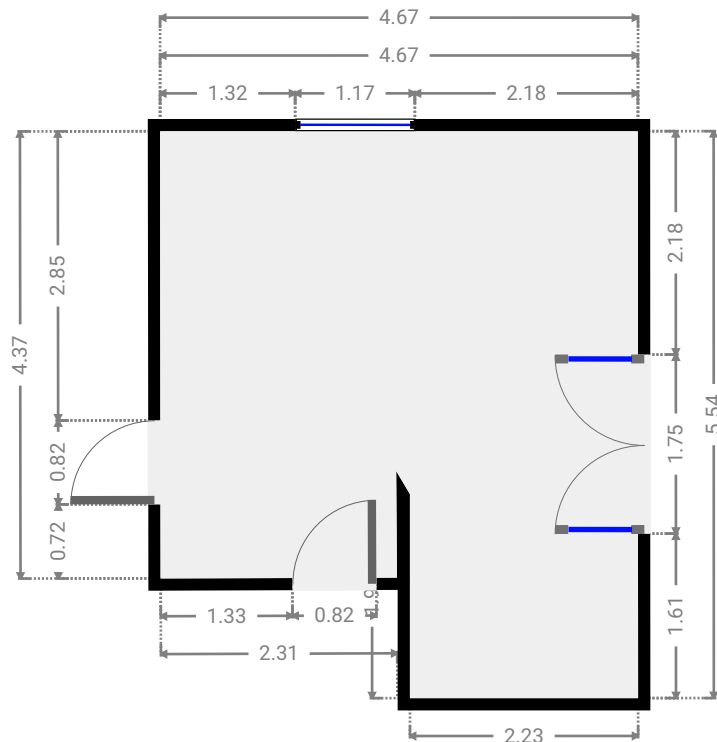
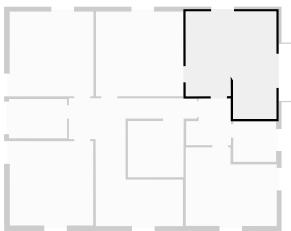

▼ Balkon 1. Stock

BREITE: 0.69 m • LÄNGE: 2.95 m
BEREICH: 2.04 m² • UMFANG: 7.28 m

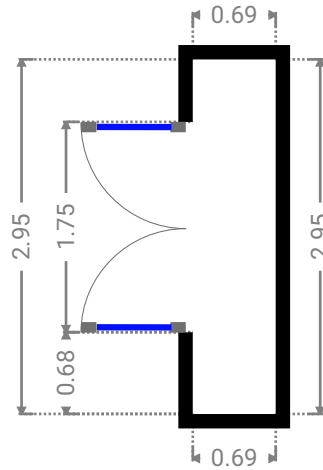
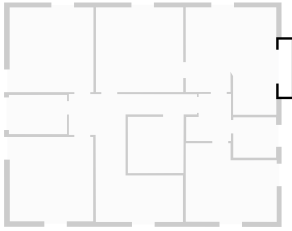

▼ Fitnessstudio 1. Stock

BREITE: 4.31 m • LÄNGE: 4.35 m
BEREICH: 18.71 m² • UMFANG: 17.30 m

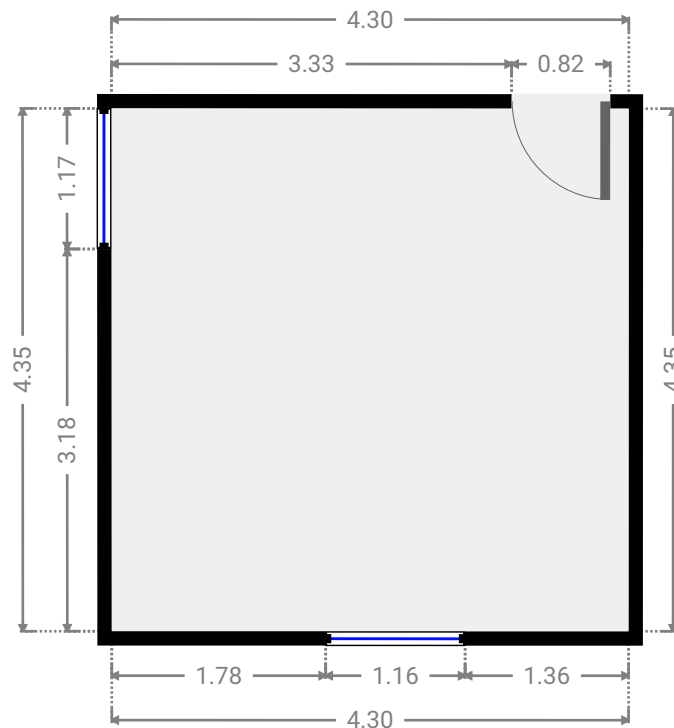
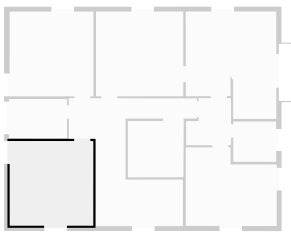

EFH Swisttal, DB

Weierstraße 27, 53913 Swisttal, Nordrhein-Westfalen, Deutschland
STOCKWERKE: 3 • RÄUME: 11



▼ Flur 1. Stock

BREITE: 2.31 m • LÄNGE: 2.43 m
BEREICH: 4.85 m² • UMFANG: 9.48 m

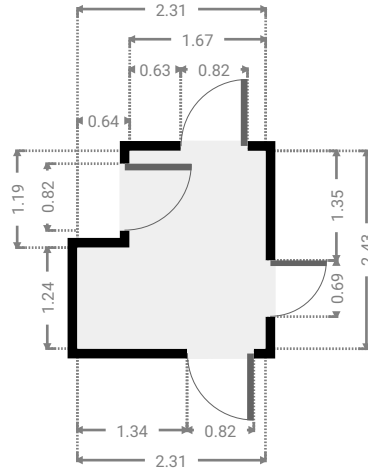
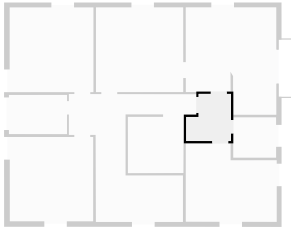

▼ Galerie 1. Stock

BREITE: 6.61 m • LÄNGE: 6.60 m
BEREICH: 24.01 m² • UMFANG: 32.31 m

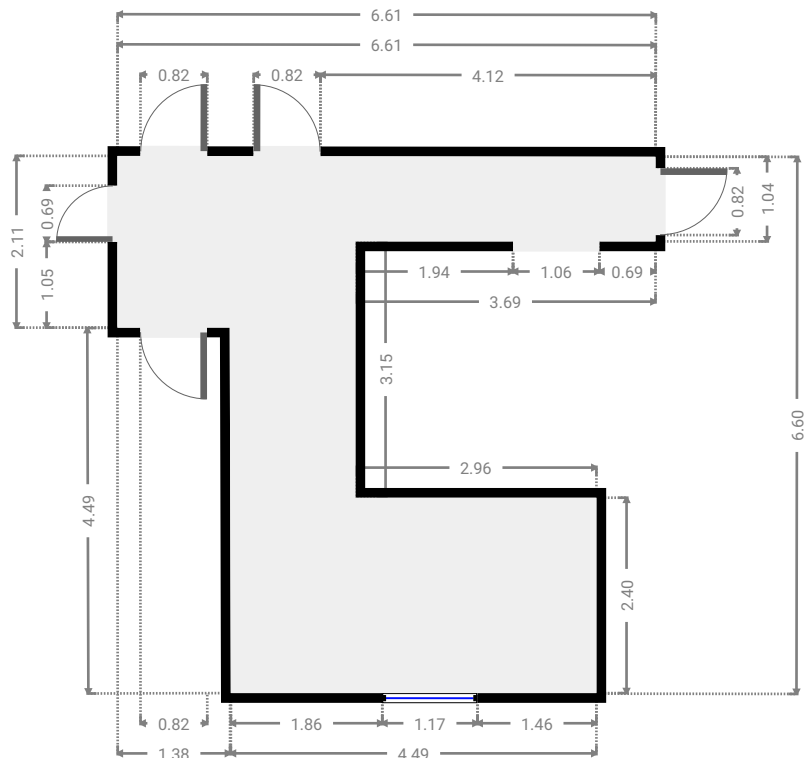
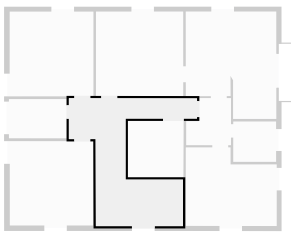

▼ **Gästezimmer**
 1. Stock

BREITE: 4.69 m · LÄNGE: 4.06 m
 BEREICH: 16.92 m² · UMFANG: 17.49 m

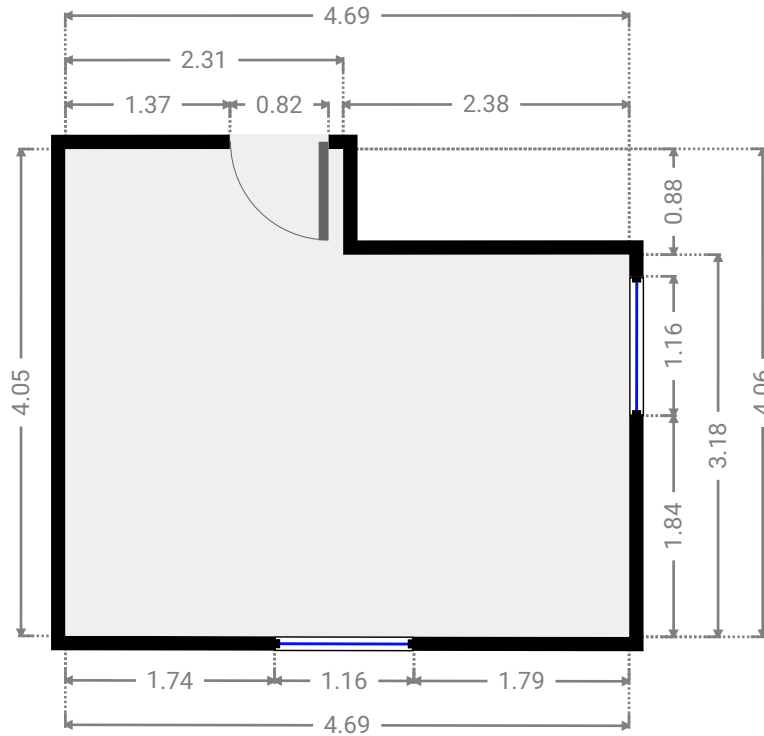
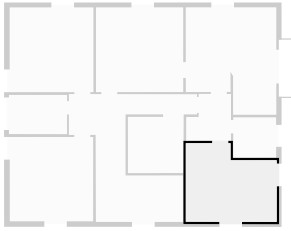

▼ **Kinderzimmer**
 1. Stock

BREITE: 4.50 m · LÄNGE: 4.37 m
 BEREICH: 19.67 m² · UMFANG: 17.74 m

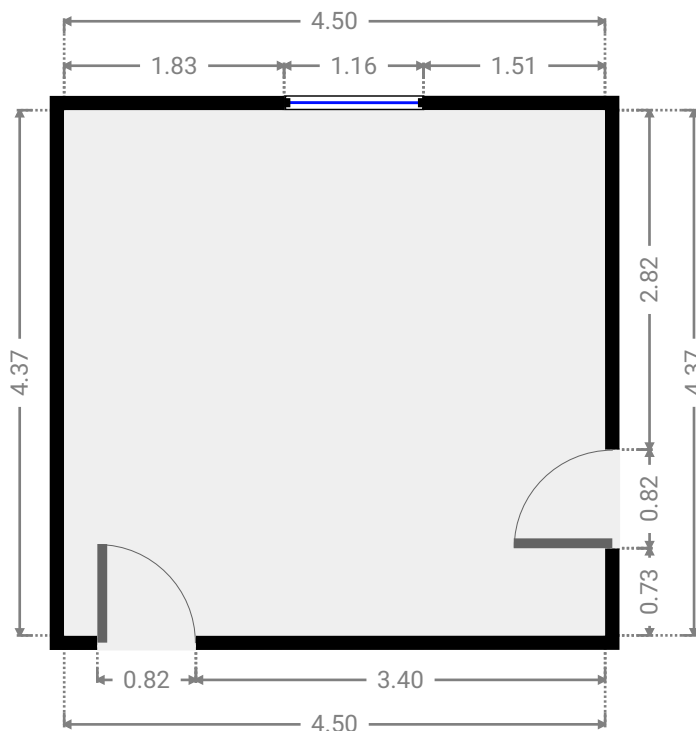
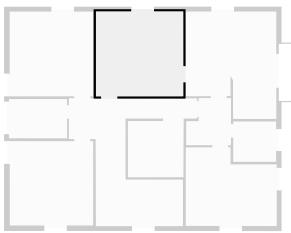

EFH Swisttal, DB

Weierstraße 27, 53913 Swisttal, Nordrhein-Westfalen, Deutschland
STOCKWERKE: 3 · RÄUME: 11

▼ Treppenhaus 1. Stock

BREITE: 2.88 m · LÄNGE: 2.90 m
BEREICH: 8.33 m² · UMFANG: 11.54 m

